

ETSL Validation report type:

Visual Stimulus Presentation and Response Registration Accuracy

System:

Experimental Run-Time System (ERTS) version 3.33 by Berisoft Cooperation

Response devices:

Berisoft ExKey and four button response pad

Report date: 29.07.2002 **Author:** Dr Richard R. Plant

Document ref: ETSL/ERTS3.33/RP/20020729

Summary: *The purpose of the Visual Stimulus Presentation and Response Registration Accuracy test is to check how accurately responses are registered in relation to visual stimuli being presented on a standard CRT. This test also measures how accurately stimulus onset, duration and offset can be controlled, and whether these drift over time, or vary with type and size of image.*

As part of the validation the response device used is tested using an oscilloscope and signal generator. This is done in order to establish its contribution to response registration timing.

Benchmark Definition: ERTS was programmed to present all stimuli for 6,000ms with an ISG (Inter Stimulus Gap, or off period) of 500ms between each presentation and response. That is, upon a response ERTS was programmed to terminate stimulus display (black screen), wait 500ms and then display the next stimulus in the sequence.

Fig 1, A sample stimulus image



Table 1, Visual stimulus materials tested

Code	Size	Colour depth	% Screen	Memory size (k)	Type
A	40x30	8	5	1.17	Block
B	200x150	8	5	29.3	Pattern
C	400x300	8	50	117.2	Pattern
D	200x150	8	25	30.3	Photo
E	400x300	8	50	118.2	Photo
F	600x450	8	75	264.7	Photo
G	800x600	8	100	469.7	Photo

A total of six individual response schedules were used. These define the response interval after a stimulus has been detected. All simulated responses have a duration of 50ms (key down, or on period).

Table 2, Simulated response schedule relative to visual stimulus leading edge

Schedule	Target Range	Actual Min	Actual Max
RALL	1 to 5000	3	4999
R250	1 to 250	2	250
R500	251 to 500	253	499
R1000	501 to 1000	505	999
R2500	1001 to 2498	1088	2498
R5000	2501 to 5000	2505	4998

*Note: All timings are in milliseconds

A total of 80 trials were run with each combination of stimulus and response schedule. In total 3360 trials were completed.

A graphical representation of a block of 80 trials is shown below.

Fig 2, A typical visual stimulus-response schedule shown graphically

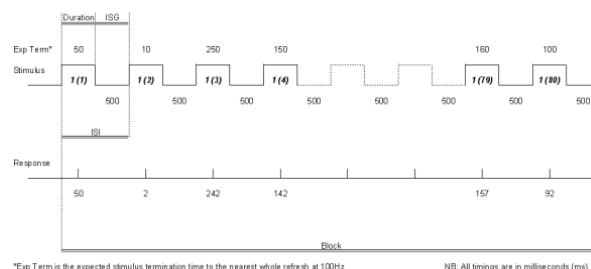

Equipment Used: Three main groups of equipment were used. The first was our standard benchmarking rig, the second the PC running ERTS and thirdly standard bench electronics for assessing the timing accuracy of the ExKey.

Benchmarking Rig

Athlon 900Mhz, 512Mb RAM (PC133), Leadtek Geforce 2 MX (32Mb AGP 2x), 82Gb HD, AC97 sound using integrated VIA chipset. Windows 2000 Pro SP2. 19" NEC VR19 monitor run at 1280x1024x24bit @ 85Hz. 8x Goldstar IDE CDR. NI 6533 and NI 6601 PCI cards.

Fig 3, An overview of how the ETSL rig interacted with the PC running ERTS

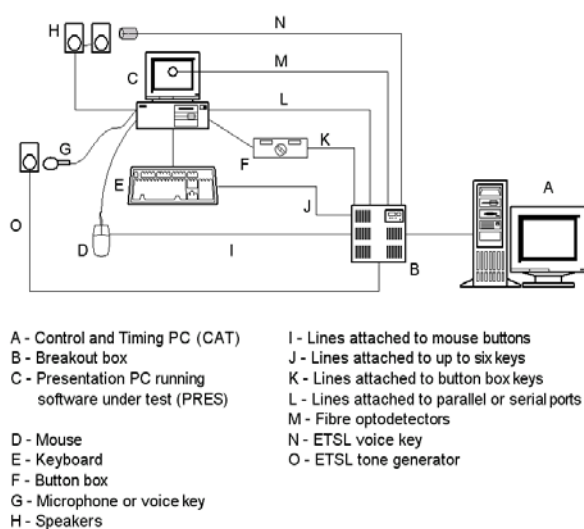

Capture and response devices are patched to a custom built breakout box. This in turn is connected to a National Instruments (www.ni.com) 6533 (DIO-32HS) PCI card, which is connected internally to a NI PCI-6601 counter timer via their RTSI (Real Time Send Interface). This PC runs our own custom written benchmarking suite or applications and talks directly to both cards using NI DAQ driver version 6.7. The rig has been externally validated as having sub-millisecond accuracy for measurement and control functions.

In the case of ERTS the ExKey (K) was patched to our breakout box (B). Fibre optic cables (M) were attached to the screen of the PC running ERTS (C). This enabled us to simulate responses based on inputs from the fibre optic cable. All monitoring and simulation was accomplished with sub-millisecond accuracy.

ERTS

ERTS v3.33 (C in figure 3), ExKey logic with four button response pad.

P120 (Pentium one), 32Mb RAM (EDO), ATI Xpression (2Mb PCI), 1.2Gb HD, ISA SoundBlaster 16. Windows 95 OSR2. 17" NEC VR17 running in 800x600x256 @ 100Hz via ERTS VESA modes. 100Hz gives a 10ms screen redraw time.

Electronic Bench Equipment

In order to evaluate the contribution made to response timing by the ExKey a Hewlett Packard (Agilent) 33120A Function/Arbitrary Waveform Generator (<http://we.home.agilent.com/>) and a Tektronix Digital Phosphor Oscilloscope (DPO) Model No TDS 3034 (<http://www.tektronix.com/>) were used.

Procedure: In order to test the contribution to timing made by the ExKey a HP function generator was used to generate accurate digital pulses which, via a transistor, were used to simulate button or key down events of known frequency and duration. A Tektronix DPO was used to record both this input pulse and the resulting data generated by the device under test.

To test the Visual Stimulus Presentation and Response Registration Accuracy of ERTS when using the ExKey as a response device, ERTS was programmed to display various stimuli repeatedly at predetermined times and for predetermined durations (see benchmark definition section).

Our benchmarking rig 'detects' visual stimuli via a fibre optodetector attached to the centre of the screen of the PC running ERTS and records all presentation timings (see fig 3). At predefined intervals relative to each stimuli's leading edge a response is simulated and fed in to the ExKey as if it had been generated by a human (see table 2).

The ETSL benchmarking rig has the ability to control simulated response onset and duration to a sub-millisecond level. To administer this benchmark we used our own in-house VSCAR (Visual Stimulus Capture And Response) software.

Observed display timings were compared with those programmed in to ERTS. Simulated response timings were then compared with those recorded by ERTS.

Results: The timing characteristics of the ExKey are presented first. These are followed by response target error data. That is, how many milliseconds difference there is between the time ERTS recorded the simulated response and the time it was actually generated relative to a stimulus appearing. Finally data on stimulus duration are given.

ExKey Logic

Table 3, The ExKey’s internal hardware timing characteristics

	Min	Max
Key down latency	92 micro secs	240 micro secs

Transmission time was constant at around 15 micro seconds by virtue of the ExKey operating via the parallel port.

Note that response pad debounce times were not tested. Switch manufacturer data suggest these are at maximum 0.2ms.

Response Target Error

Generally Response Target Errors were extremely small with very high consistency. It should be noted that all response data and graphs displayed are for uncorrected Response Target Errors. Put simply ERTS starts recording response time data from when the image starts to draw on the CRT, i.e. top left downwards. Our fibre optodetectors were attached centre screen so as to be centred on the visual stimulus which was also centre screen. With the CRT being driven at 100Hz a full screen is redrawn every 10ms. Therefore it takes around 4-5ms for the image to be drawn to the point of the fibre optodetector. Hence this time should be subtracted for all figures and graphs shown.

Table 4, Uncorrected Response Target Error over 160 trials conducted with the RALL schedule (Responses 1 to 5000ms after the leading edge of a visual stimulus)

Stimulus type	Mean Error	SD	Min Error	Max Error
40x30x256 block	3.72	0.28	3.20	4.30
800x600x256 photo	3.72	0.33	3.00	4.30

Here the effect of stimulus complexity can be seen on mean reaction time error over 80 trials. This is for the 1 to 5000ms response schedule across all bitmap sizes.

Fig 4, Effects of stimulus complexity on uncorrected Response Time Error with the RALL schedule

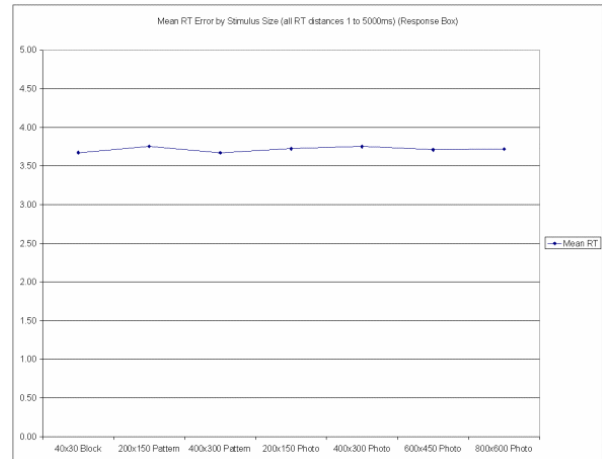

Here the effect of varying RT distance along with stimulus complexity can be seen. RT Distance is the response interval since the leading edge of a visual stimulus is detected and a response simulated. For each RT distance 80 trials were run within the range stated, e.g. 1 to 250ms etc.

Fig 5, Mean Response Time error vs stimulus complexity when using the ExKey

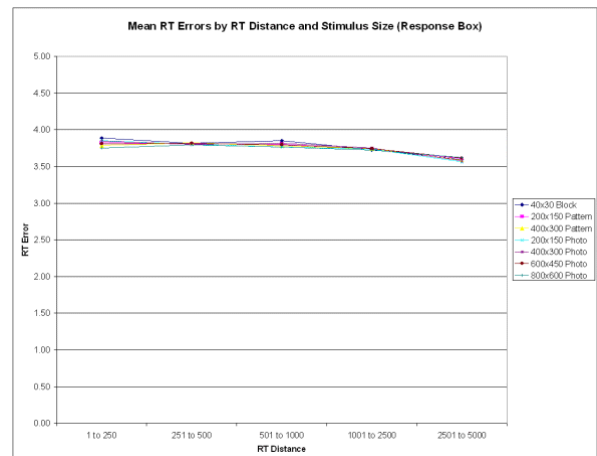

Finally the frequency of Response Time Errors is plotted for the simplest and most complex visual stimuli.

Fig 6, Distribution of Response Target Errors for simple vs complex visual stimuli

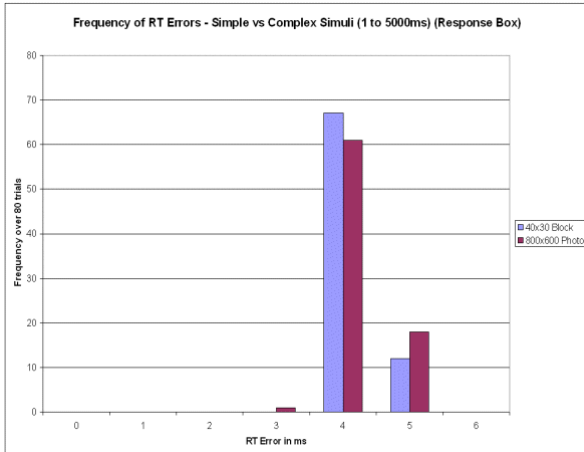

the ISG was longer than expected. Minus figures indicate it was shorter than ideal.

Fig 8, Distribution of Inter Stimulus Gap Errors (off period) for simple vs complex visual stimuli

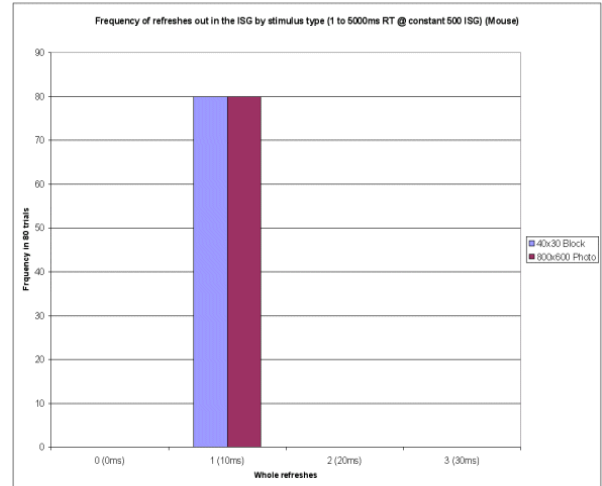

Stimulus Duration Errors

In the Stimulus-Response benchmark ERTS was programmed to terminate stimulus display on response registration. A Whole Refresh Error of 0 (zero) indicates that the stimulus was terminated at the ideal time, i.e. the end of the refresh as the beam scans to the bottom of the screen immediately after the response was registered by ERTS. Any higher positive figures indicate that the stimulus did not terminate and was displayed for longer than ideal.

Fig 7, Distribution of Display Duration Errors (on period) for simple vs complex visual stimuli

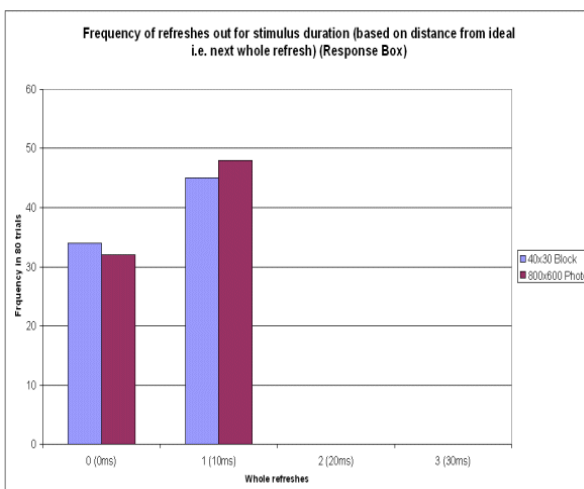

Conclusion: Even on extremely modest hardware by today’s standards ERTS performed extremely well in terms of absolute accuracy and low jitter (low Standard Deviation).

The ExKey is the fastest scanning commercial response device tested to date by ETSL meaning that it should never contribute more than a quarter of a millisecond to recorded response times.

Response times recorded by ERTS were not effected by the size of visual stimulus being displayed or by the Response Time Distance (the time allowed to elapse after the stimulus is displayed and the simulated response), see figures 4 and 5 respectively. Figure 6 reinforces this finding. All recorded data show a very low standard deviation. Remember that these are uncorrected timings and that 4 to 5 milliseconds should be subtracted from the plots to account for top of screen to fibre optodetector re-draw time. Effectively Response Target Errors are very close to zero when this correction is applied.

After a stimulus terminates ERTS was programmed to wait for 500ms before displaying the next stimulus. Again a 0 (zero) measure indicates the ISG was exactly 500ms as programmed. Any positive values indicate

In terms of stimulus display duration ERTS displayed just under half of the stimulus images for exactly the correct amount of time. That is, it terminated them during the same refresh as the response was registered. It is thought that the remaining images that were displayed for one refresh too long were the result of the response being too near the end of the refresh for a termination action to be scheduled by ERTS.

All Inter Stimulus Gaps (off periods) were consistently one refresh too long.